



Engineering Products

Signiatec

®

Sign Manufacture Large Format Digital Printing Graphic Design Engineering Site Surveying Installation

Signiatec Ltd, Kiltorcan Business Park, Ballyhale, Co. Kilkenny, Ireland.

T: +353 (0)56 7766648

E: info@signiatec.ie W: www.signiatec.ie

Signiatec

®

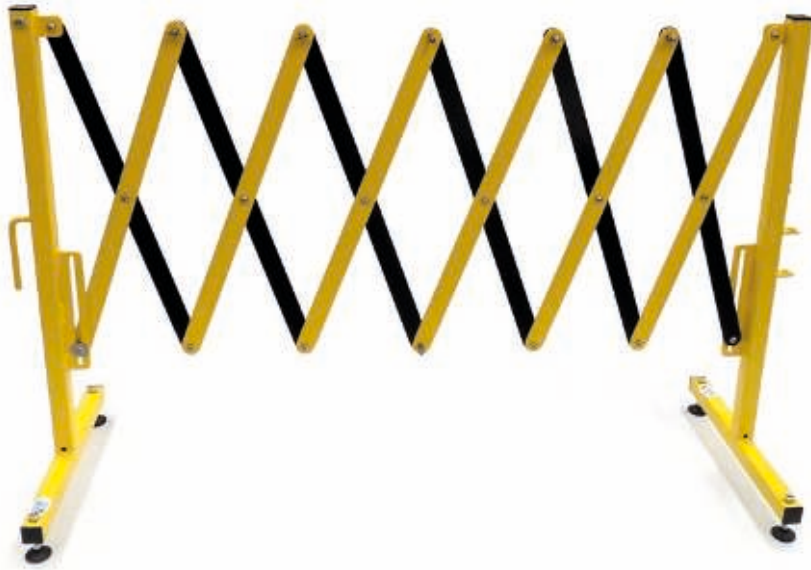

- Available in a variety of colour combinations for hazard identification.
- Compact frame - 450mm wide when closed. Opens out to over 3.25m when open. 1m to top of barrier.
- Fitted with drop latch to keep closed when transporting.
- Fitted with hook and receivers for attaching barrier to barrier.
- Mild steel construction - fully galvanised to BS EN ISO 1461:2009.
- Powder coated paint finish.
- Box sections fitted with plastic cap ends.
- Additional mild steel sections can be added to extend to 5m if required.
- Custom sign message can be attached to extendable barrier.



For more information contact us at:

Signiatec Ltd, Kiltorcan Business Park, Ballyhale, Co. Kilkenny, Ireland.

Telephone: +353 (0)56 7766648 Email: info@signiatec.ie Web: www.signiatec.ie



- Aluminium construction - fully sealed.
- Powder coated paint finish.
- Manufactured to whatever size required.
- Optional Tool Tray, internal shelving and display frames can be added for important messages.

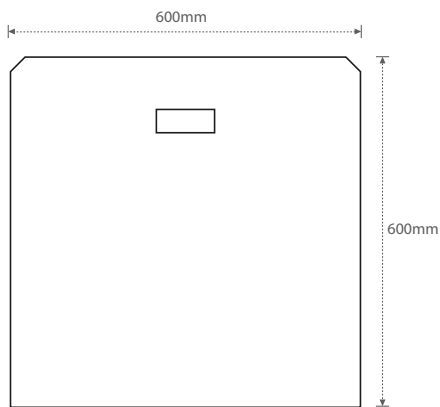

Side profile

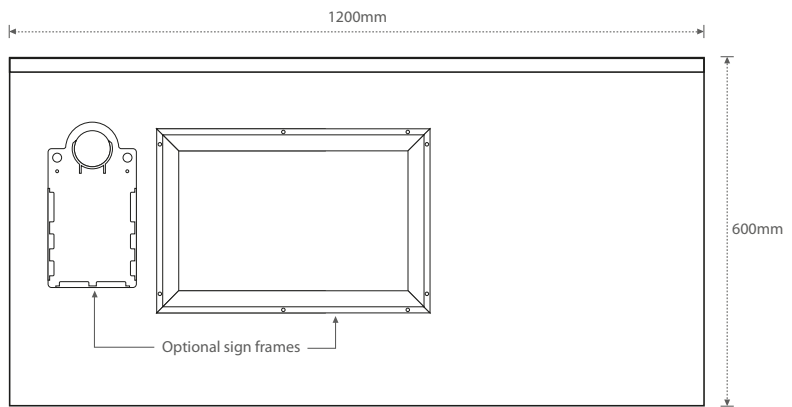

Front profile

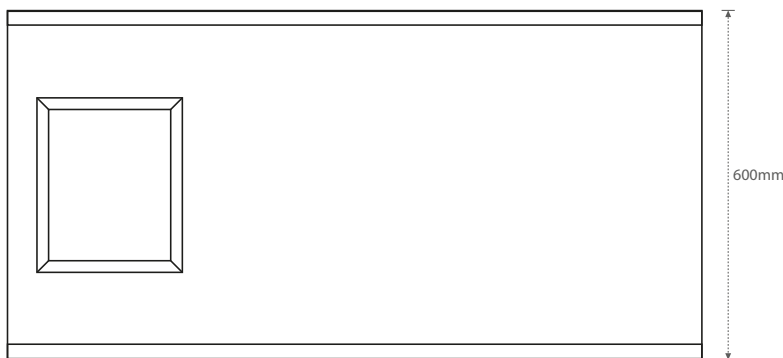

Top profile

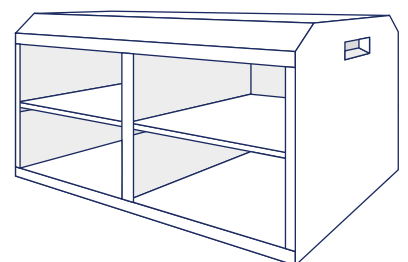
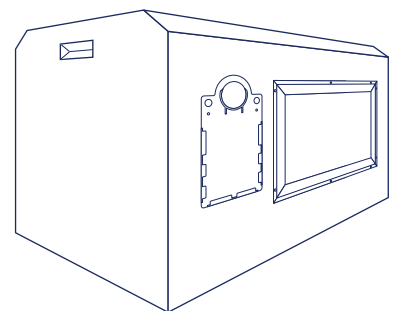

For more information contact us at:

Signiatec Ltd, Kiltorcan Business Park, Ballyhale, Co. Kilkenny, Ireland.

Telephone: +353 (0)56 7766648 Email: info@signiatec.ie Web: www.signiatec.ie

Signiatec

®



- Aluminium construction - fully sealed.
- Powder coated paint finish.
- Extendable width allows for more flexibility on site by site basis.
- Measurement indicator included with maximum extension marked in red.
- Stackable.
- For further information, please contact us on the number below.



For more information contact us at:

Signiatec Ltd, Kiltorcan Business Park, Ballyhale, Co. Kilkenny, Ireland.

Telephone: +353 (0)56 7766648 Email: info@signiatec.ie Web: www.signiatec.ie

© Signiatec Ltd



- Mild steel construction - fully galvanised to BS EN ISO 1461:2009.
- Manufactured to whatever size required.
- Powder coated paint finish.
- Swivel support legs for quick setup.
- Modular components come apart easily for ease of storage and transport.

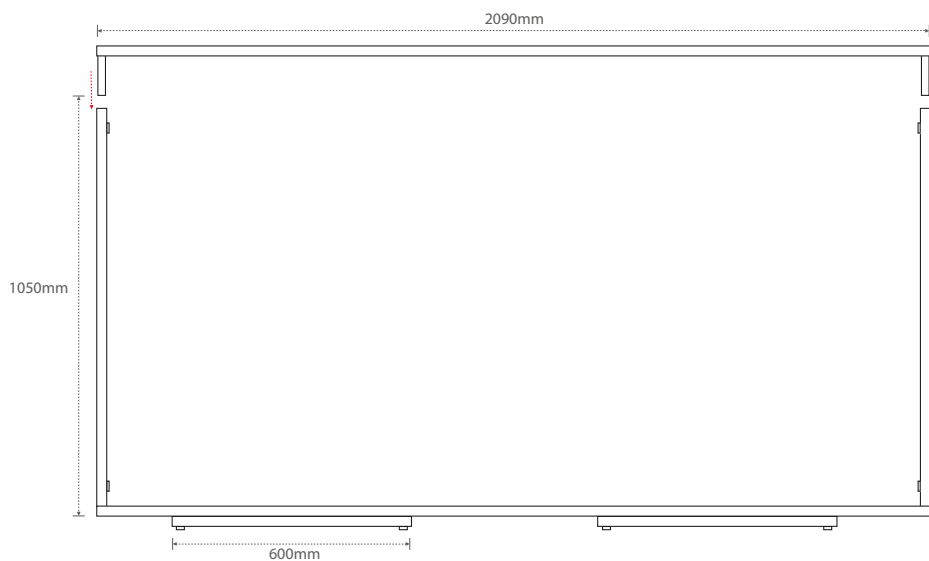
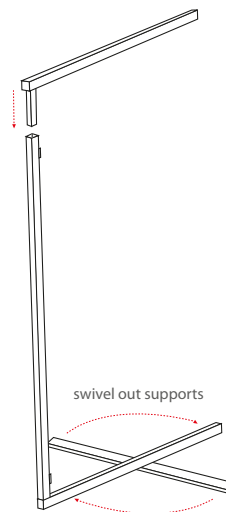
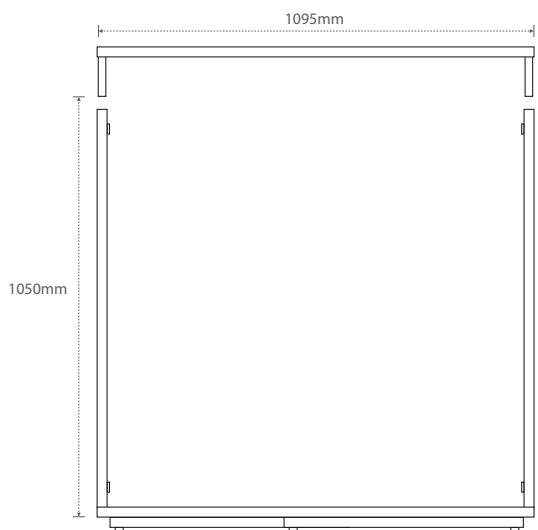

For more information contact us at:

Signiatec Ltd, Kiltorcan Business Park, Ballyhale, Co. Kilkenny, Ireland.

Telephone: +353 (0)56 7766648 Email: info@signiatec.ie Web: www.signiatec.ie



Front face



Rear face

- Mild steel construction - fully galvanised to BS EN ISO 1461:2009. Aluminium face.
- Powder coated paint finish.
- Any size barrier can be made to meet your needs
- Fitted with hook and receivers for attaching barrier to barrier.
- Swivel support legs for quick setup.
- Graphics/logo or message can be added to aluminium face.

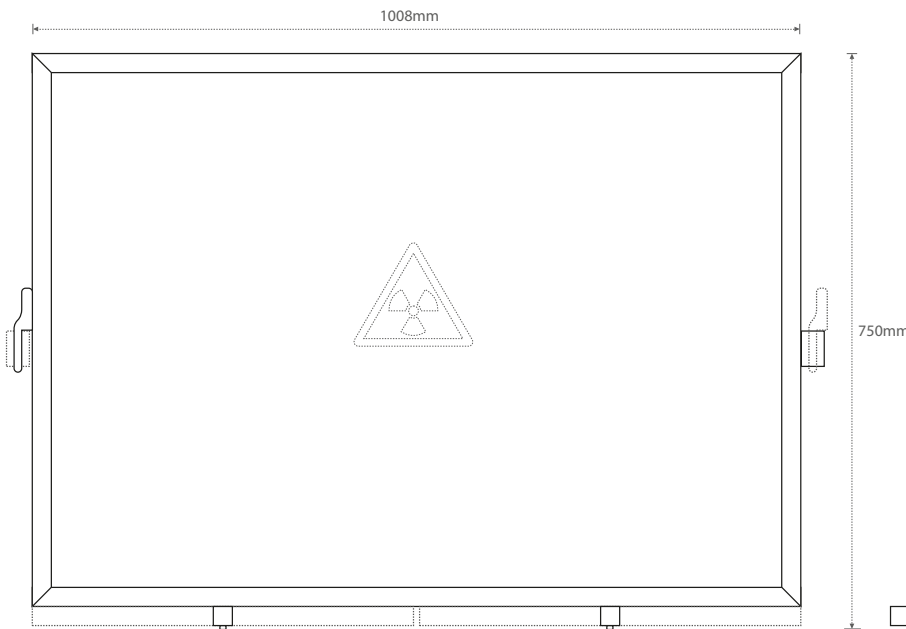

Front profile

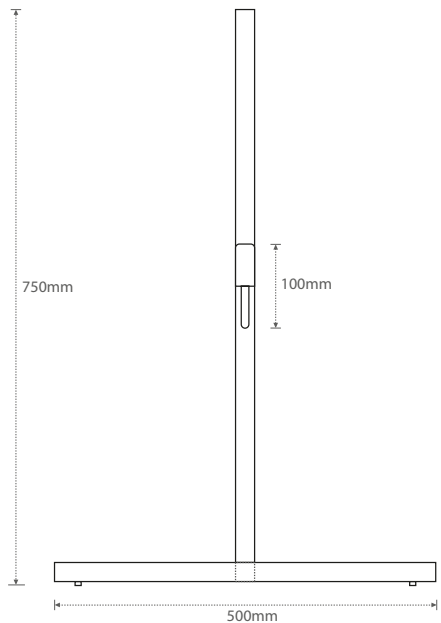

Side profile

For more information contact us at:

Signiatec Ltd, Kiltorcan Business Park, Ballyhale, Co. Kilkenny, Ireland.

Telephone: +353 (0)56 7766648 Email: info@signiatec.ie Web: www.signiatec.ie



Front face



Rear face



- Mild steel construction - fully galvanised to BS EN ISO 1461:2009. Aluminium face.
- Powder coated paint finish.
- Any size barrier can be made to meet your needs
- Fitted with hook and receivers for attaching barrier to barrier.
- Swivel support legs for quick setup.
- Graphics/logo or message can be added to aluminium face.

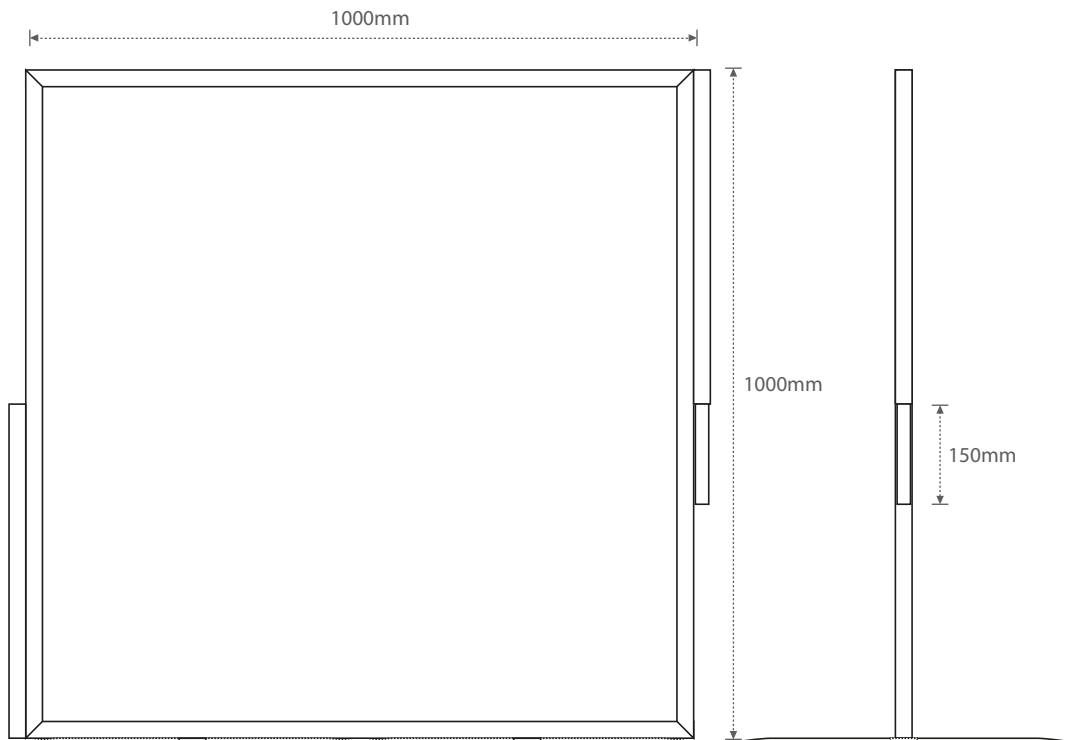

Front profile

Side profile

For more information contact us at:

Signiatec Ltd, Kiltorcan Business Park, Ballyhale, Co. Kilkenny, Ireland.

Telephone: +353 (0)56 7766648 Email: info@signiatec.ie Web: www.signiatec.ie



Front face



Rear face

- Mild steel construction - fully galvanised to BS EN ISO 1461:2009.
- Powder coated paint finish.
- Any size barrier can be made to meet your needs
- Fitted with hook and receivers for attaching barrier to barrier.
- Swivel support legs for quick setup.
- Graphics/logo or message can be added to PVC.

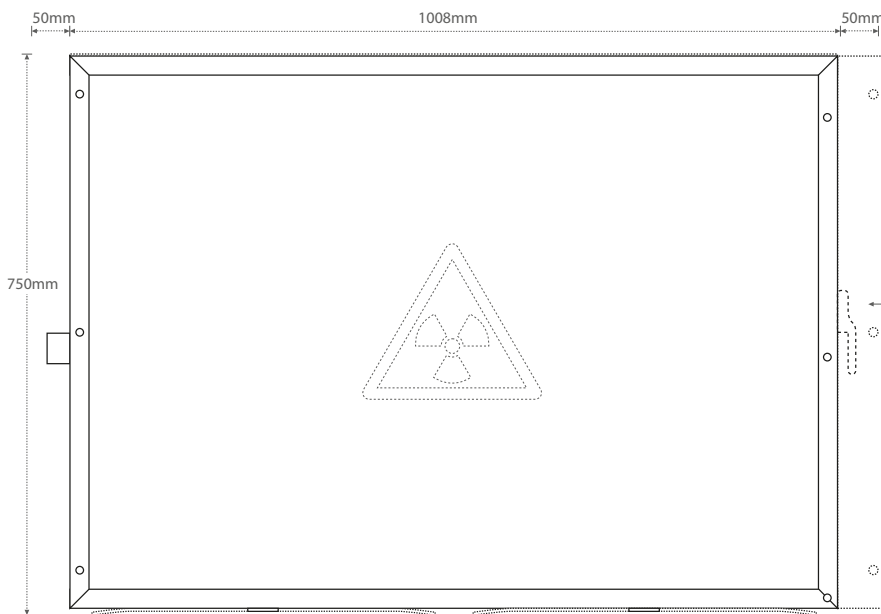

Front profile

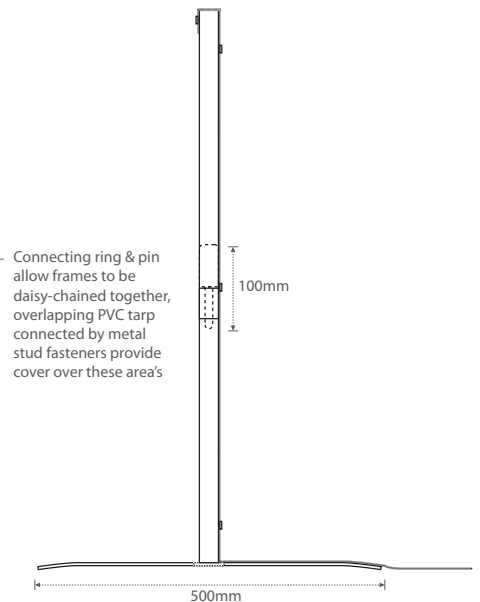

Side profile

For more information contact us at:

Signiatec Ltd, Kiltorcan Business Park, Ballyhale, Co. Kilkenny, Ireland.

Telephone: +353 (0)56 7766648 Email: info@signiatec.ie Web: www.signiatec.ie

Signiatec

®



- Designed for use with protective lead blanket.
- Available in a variety of colour combinations.
- Mild steel construction - fully galvanised to BS EN ISO 1461:2009.
- Powder coated paint finish.
- Any size rack can be made to meet your needs with hooks on both sides.
- Supplied with braked castors for transport ease from location to location.

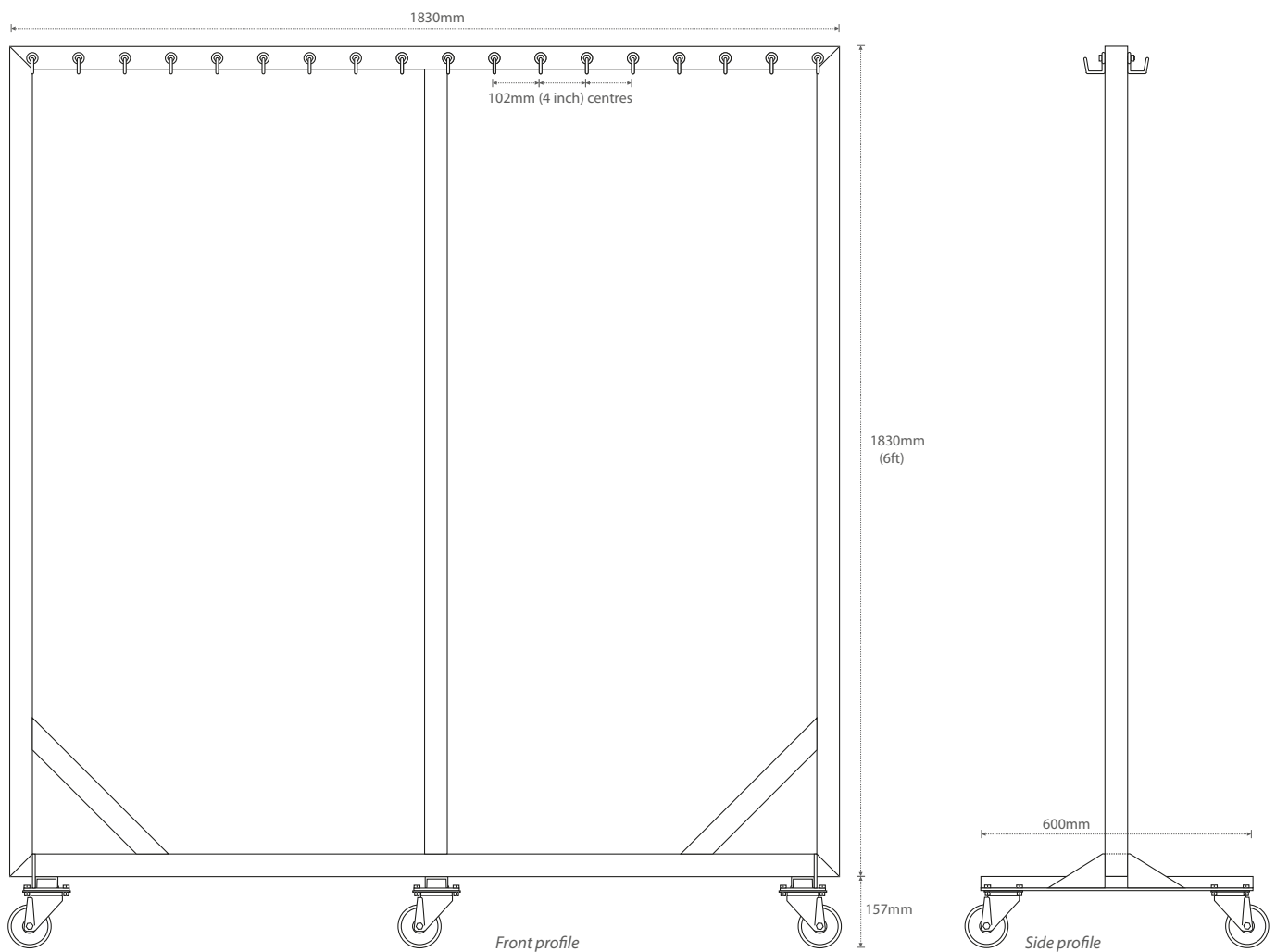

For more information contact us at:

Signiatec Ltd, Kiltorcan Business Park, Ballyhale, Co. Kilkenny, Ireland.

Telephone: +353 (0)56 7766648 Email: info@signiatec.ie Web: www.signiatec.ie



Signiatec

®

- Designed for use with protective lead blanket.
- Fully modular shielding frame allows for ease of transport and set-up.
- Available in a variety of colour combinations.
- Mild steel construction - fully galvanised to BS EN ISO 1461:2009.
- Powder coated paint finish.
- Any size rack can be made to meet your needs with hooks on both sides.
- Supplied with braked castors for transport ease from location to location.

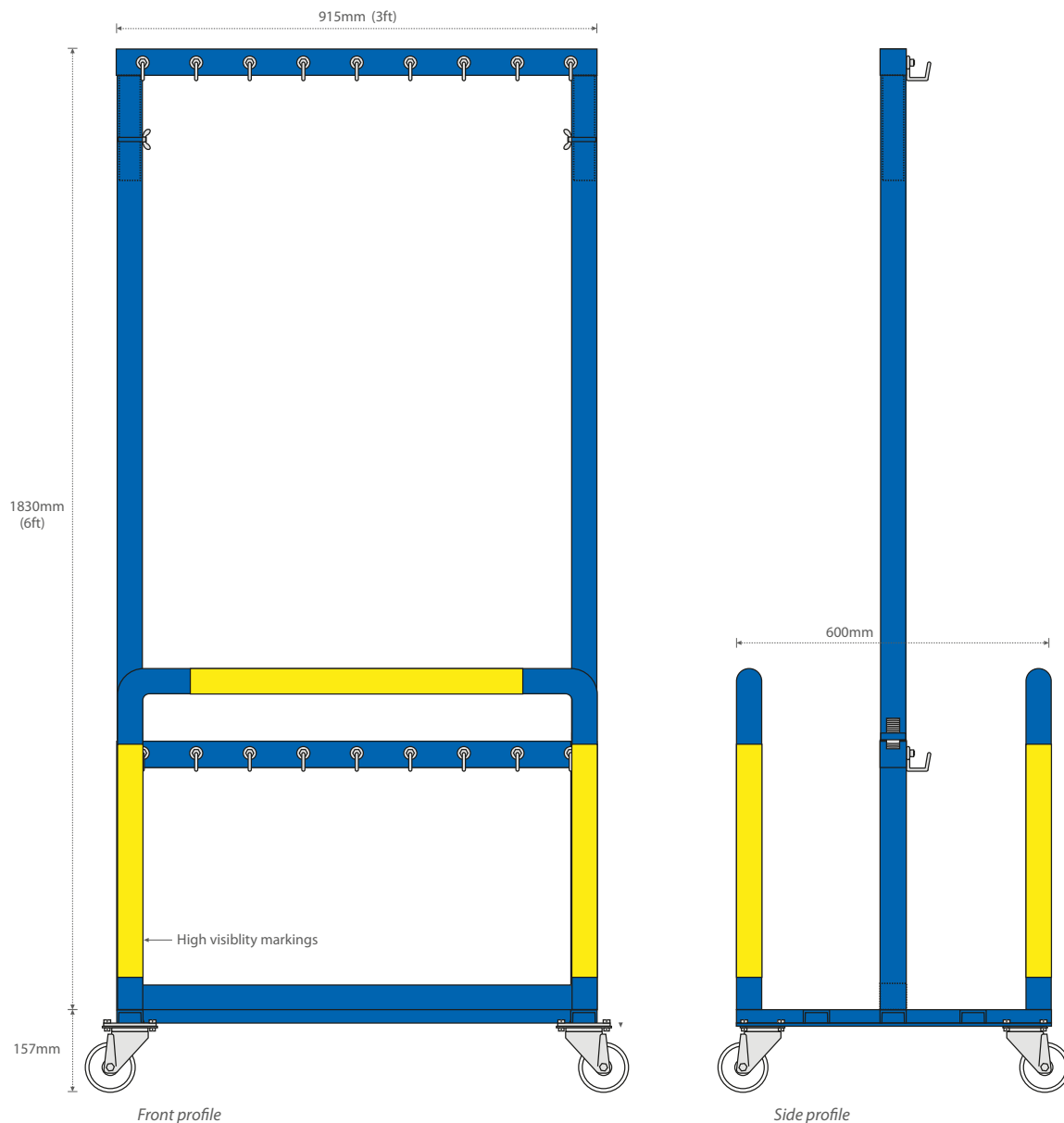

For more information contact us at:

Signiatec Ltd, Kiltorcan Business Park, Ballyhale, Co. Kilkenny, Ireland.

Telephone: +353 (0)56 7766648 Email: info@signiatec.ie Web: www.signiatec.ie



- Stainless steel construction.
- Can made to any size or design required.
- Hard wearing polycarbonate windows for quick identification of PPE equipment.
- Supplied with braked castors and lifting points for forklift.

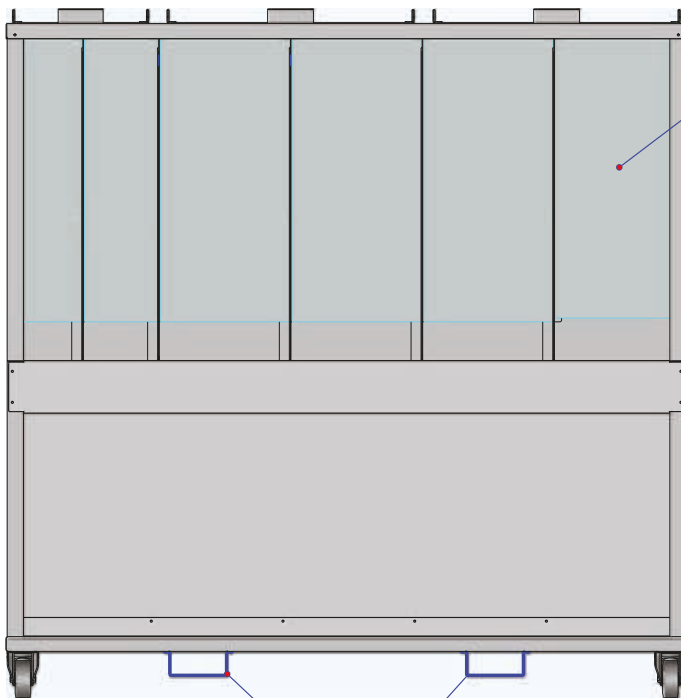

CLEAR POLYCARBONATE PANELS

FOR LIFTING POINTS

Front profile

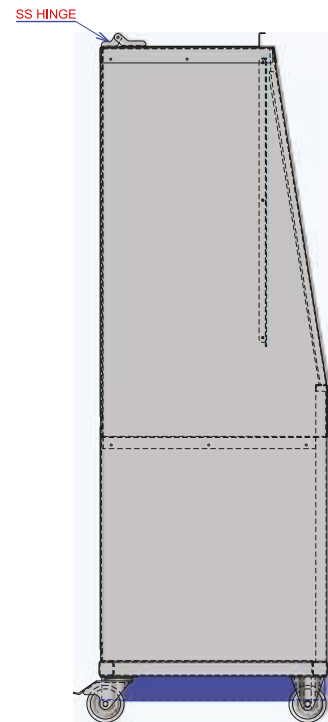

SS HINGE

Side profile

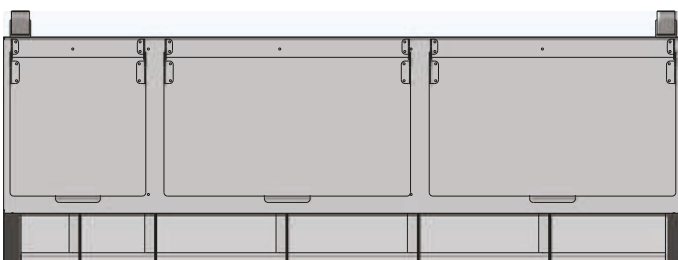

Top profile

For more information contact us at:

Signiatec Ltd, Kiltorcan Business Park, Ballyhale, Co. Kilkenny, Ireland.

Telephone: +353 (0)56 7766648 Email: info@signiatec.ie Web: www.signiatec.ie



- Aluminium construction.
- Powder coated paint finish.
- Optional support stand.
- Easy access sealed hatch protects masks from dusty environment and indicator window lets you know when stock needs refilling.

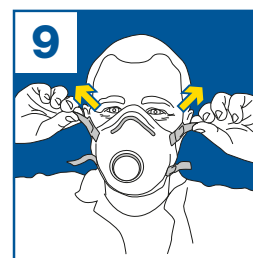
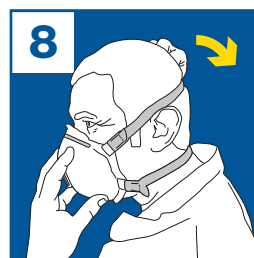
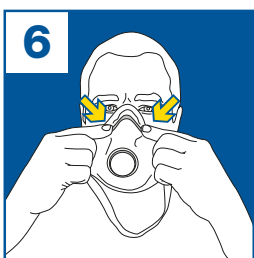

- Aluminium construction.
- Can made to any size or design required.
- Powder coated paint finish.
- Includes lockable sliding drawers and hinged doors with shelved storage space.

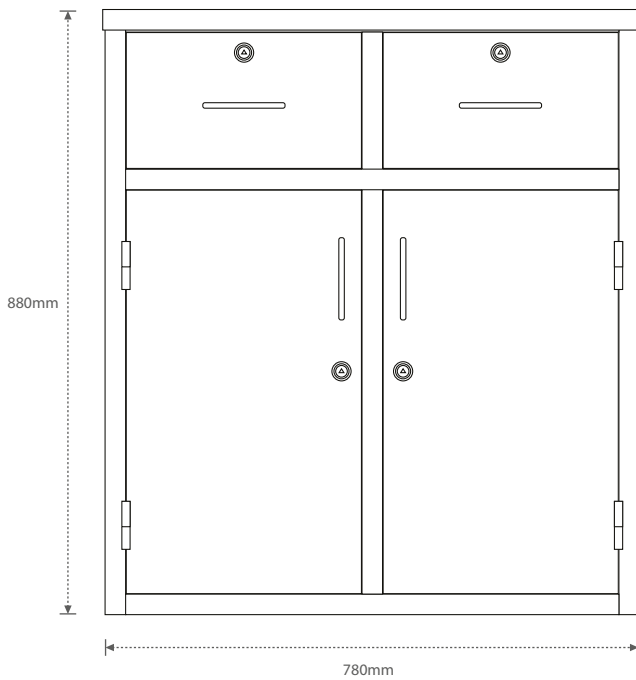

front profile

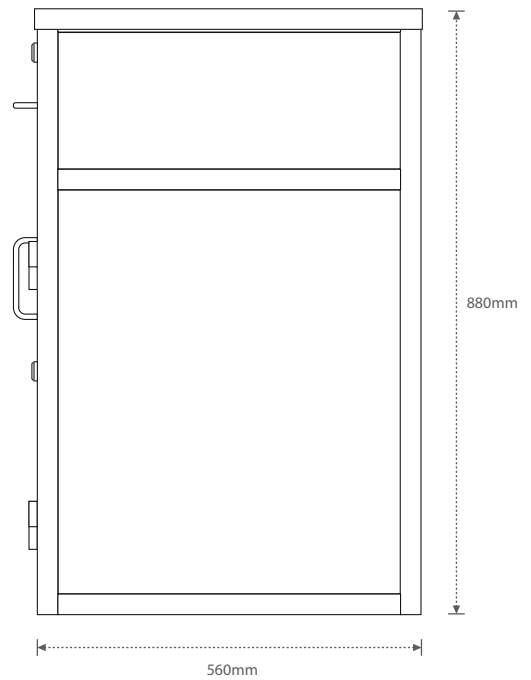

side profile

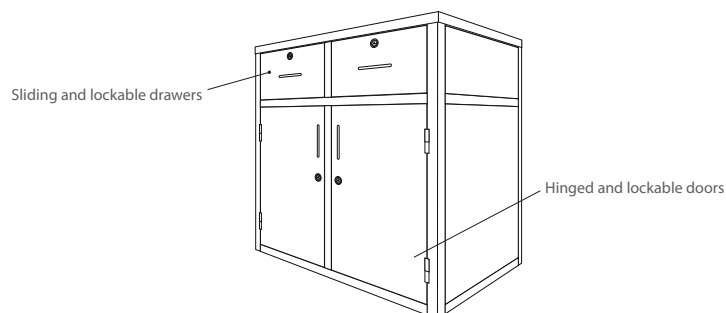

For more information contact us at:

Signiatec Ltd, Kiltorcan Business Park, Ballyhale, Co. Kilkenny, Ireland.

Telephone: +353 (0)56 7766648 Email: info@signiatec.ie Web: www.signiatec.ie



Signiatec

®

- Collapsible bag stand, O-type
- Plastic coated for protection against rust and scratches
- Material: round steel 3/8"
- Ideal for bags wider than 73 cm
- Simple dismantle, thus space saving and low transportation costs
- No screws or bolts
- No sharp edges and no points to wear bags or floors
- For fastening the opening of the bag must be wrapped around the top of the bag stand



Top: 48 cm, 71 cm high
Footprint: 48 cm x 48 cm
Approx. 2.6 kg

For more information contact us at:

Signiatec Ltd, Kiltorcan Business Park, Ballyhale, Co. Kilkenny, Ireland.

Telephone: +353 (0)56 7766648 Email: info@signiatec.ie Web: www.signiatec.ie

© Signiatec Ltd



Double ring



Single ring

- Mild steel construction - fully galvanised to BS EN ISO 1461:2009.
- Powder coated paint finish.
- Any size ring can be made to meet your needs.
- Suitable for both indoor and outdoor use.

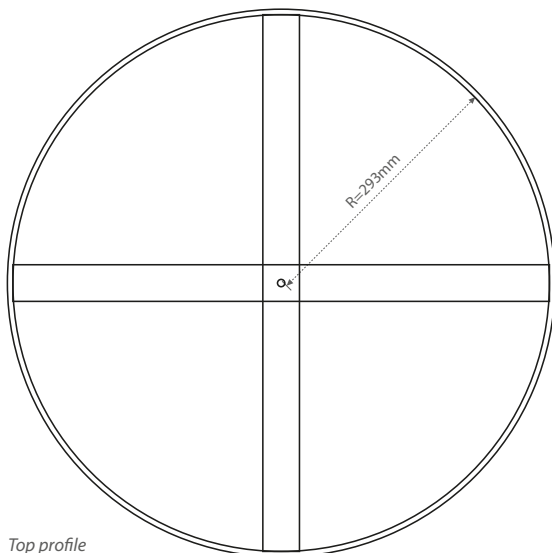

Top profile

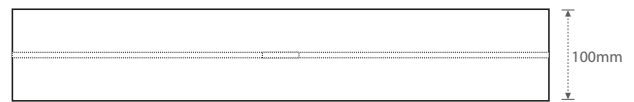

Side profile

Signiatec

®



- Mild steel construction - fully galvanised to BS EN ISO 1461:2009.
- Powder or plastic coated paint finish.
- Extendable threaded rod secures brace between barrels.
- Neoprene pads protect barrels from wear while secured in place.

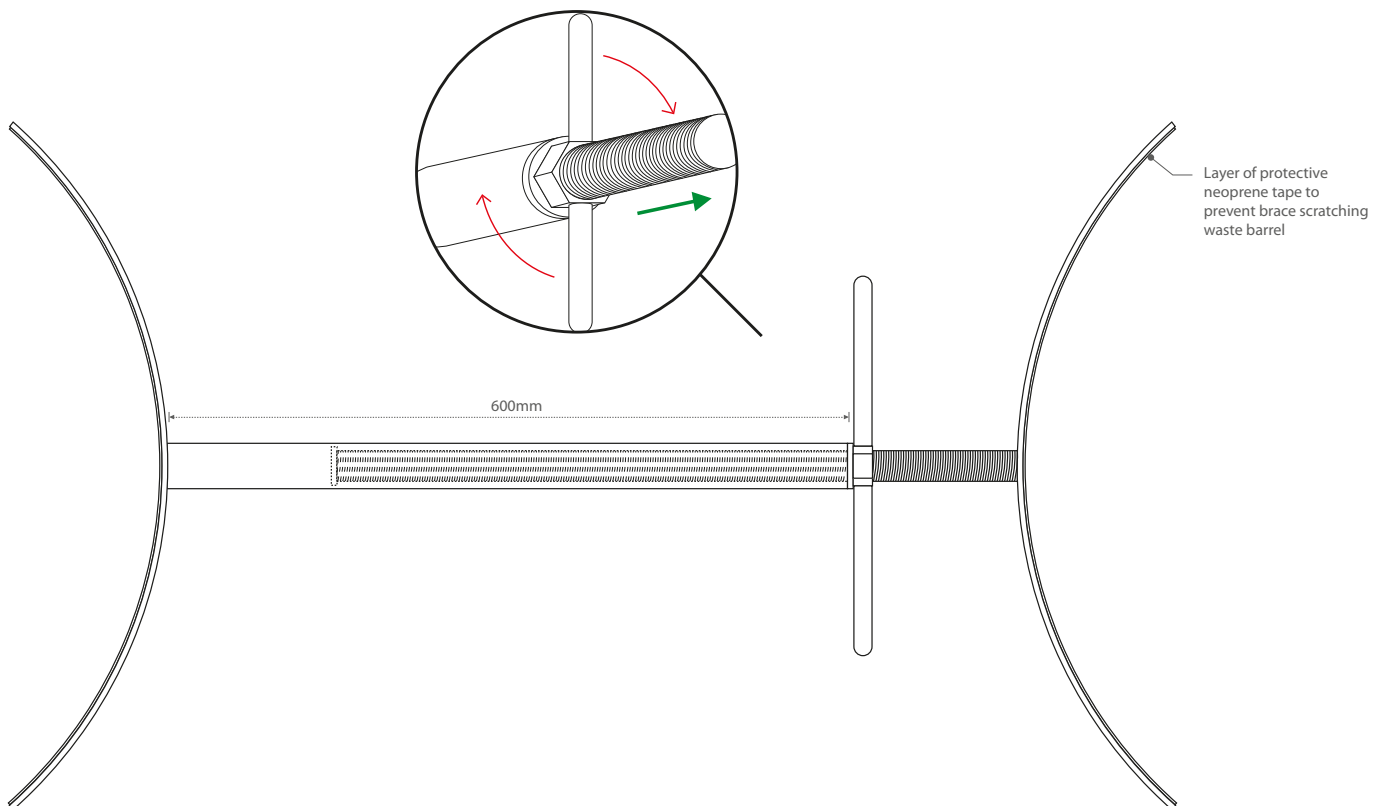

For more information contact us at:

Signiatec Ltd, Kiltorcan Business Park, Ballyhale, Co. Kilkenny, Ireland.

Telephone: +353 (0)56 7766648 Email: info@signiatec.ie Web: www.signiatec.ie

© Signiatec Ltd



- Aluminium construction.
- Powder coated paint finish.
- 30mm deep table top and neoprene insert securely hold air monitor in place.
- Optional hooks on main support to keep hose tidy.
- Modular components come apart easily for ease of storage and transport.

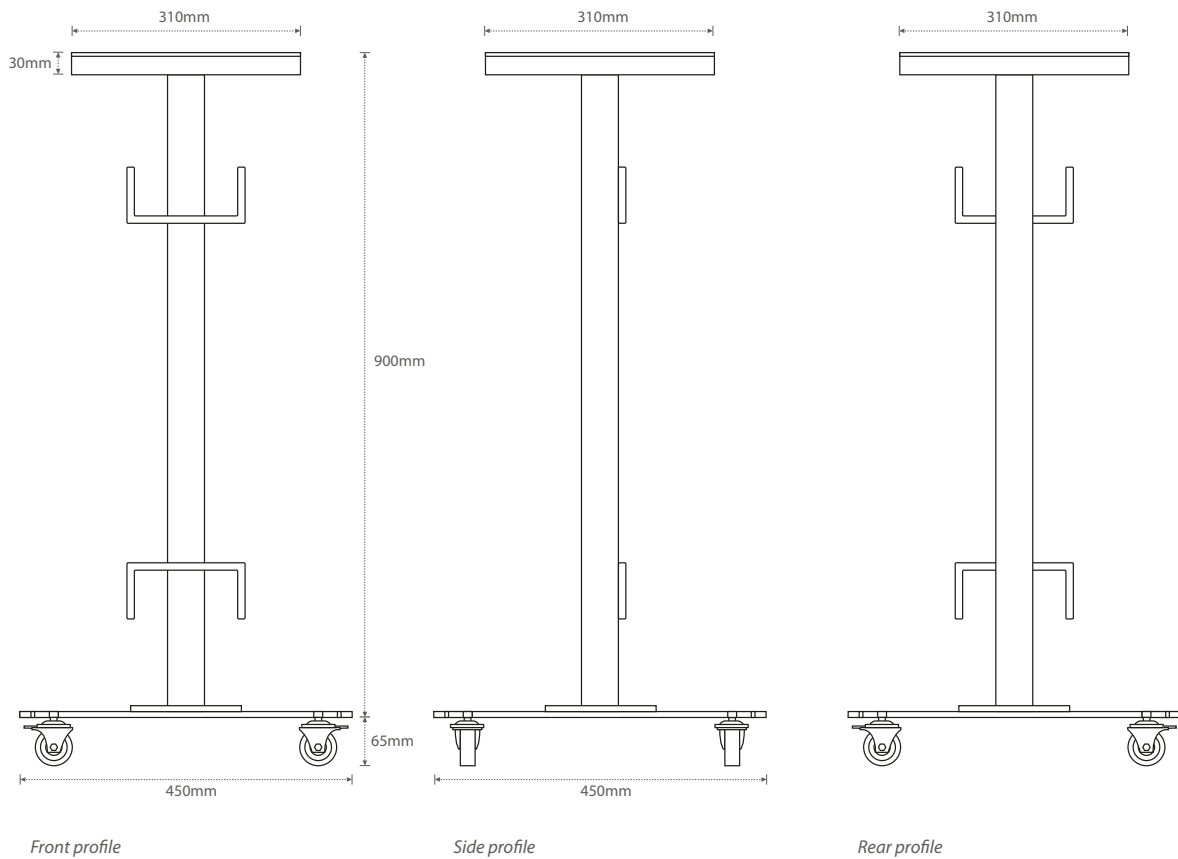

For more information contact us at:

Signiatec Ltd, Kiltorcan Business Park, Ballyhale, Co. Kilkenny, Ireland.

Telephone: +353 (0)56 7766648 Email: info@signiatec.ie Web: www.signiatec.ie

- Designed for specific purpose of clients requirements.
- Aluminium construction.
- Powder coated paint finish available.
- Supplied with braked castors for transport ease from location to location.

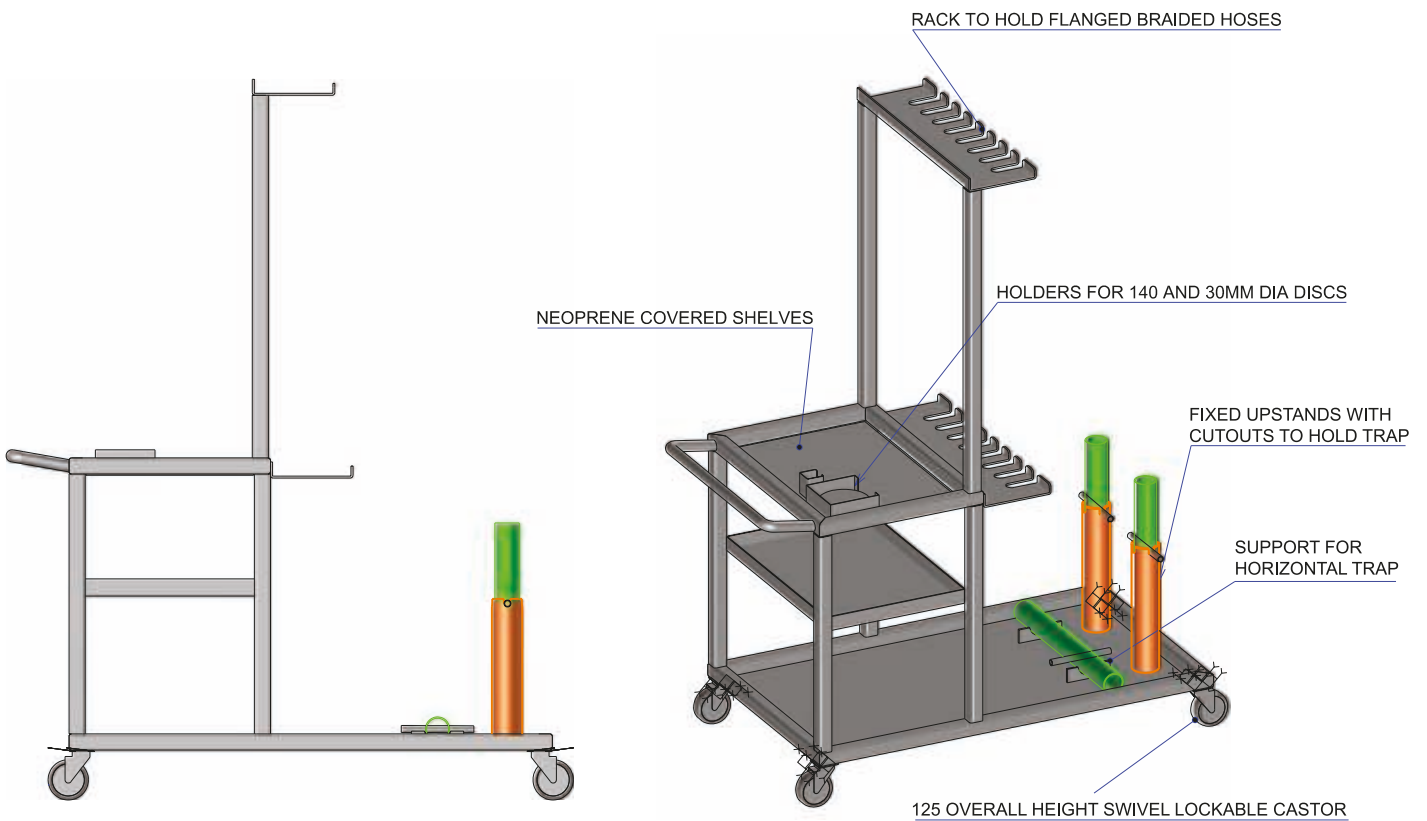

For more information contact us at:

Signiatec Ltd, Kiltorcan Business Park, Ballyhale, Co. Kilkenny, Ireland.

Telephone: +353 (0)56 7766648 Email: info@signiatec.ie Web: www.signiatec.ie

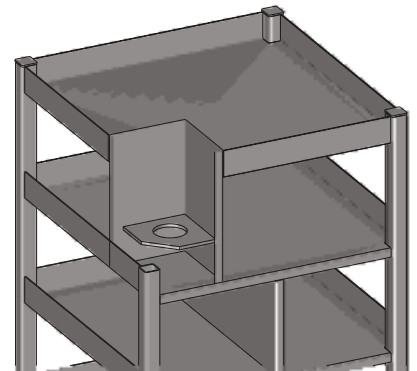
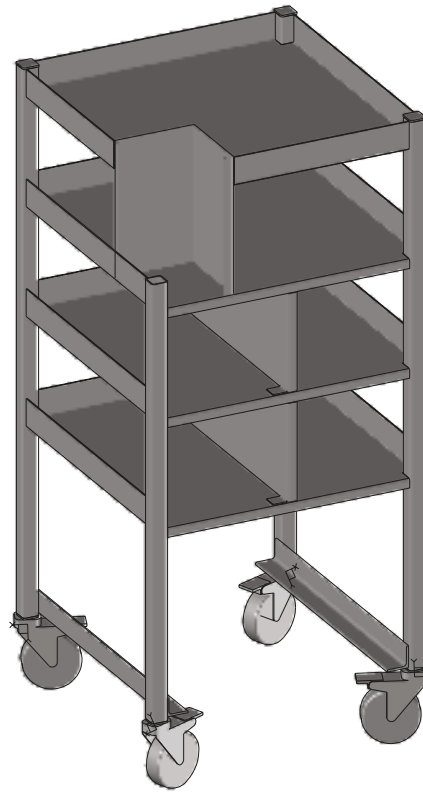
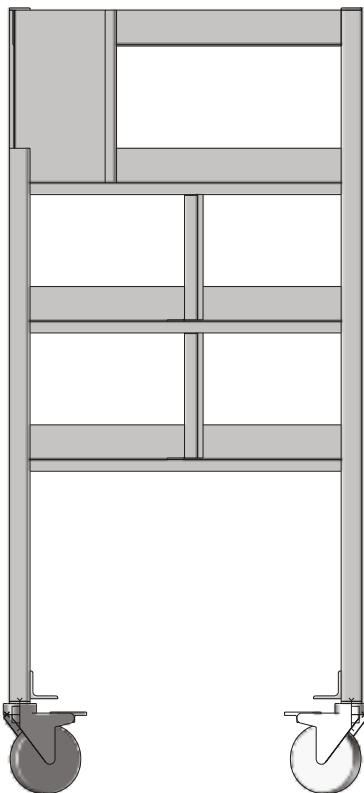

- Designed for specific purpose of clients requirements.
- Aluminium construction.
- Powder coated paint finish available.
- Supplied with braked castors for transport ease from location to location.



- Designed for use with protective lead blanket.
- Mild steel construction - fully galvanised to BS EN ISO 1461:2009.
- Powder coated paint finish.
- Supplied with braked castors for transport ease from location to location.

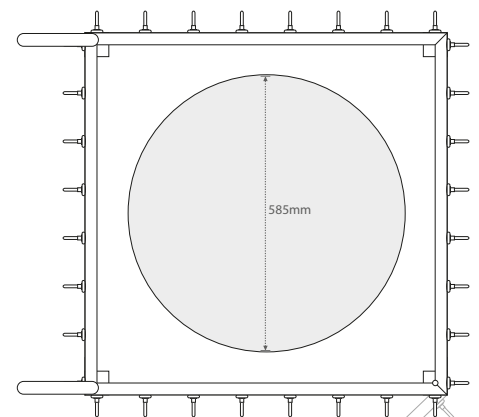

Plan view

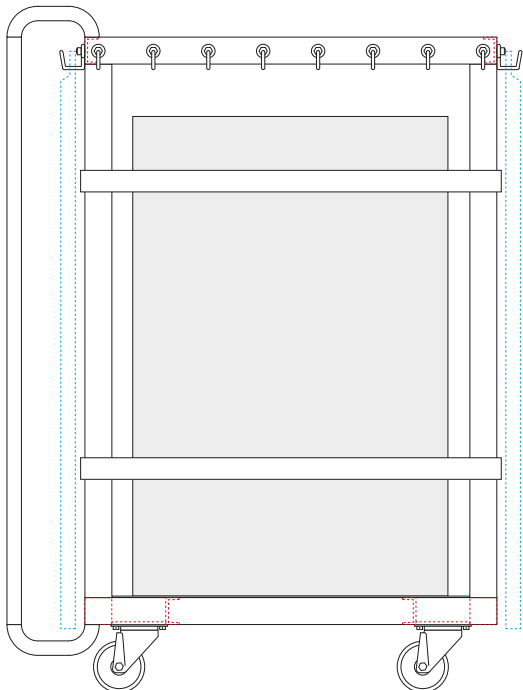

Side profile

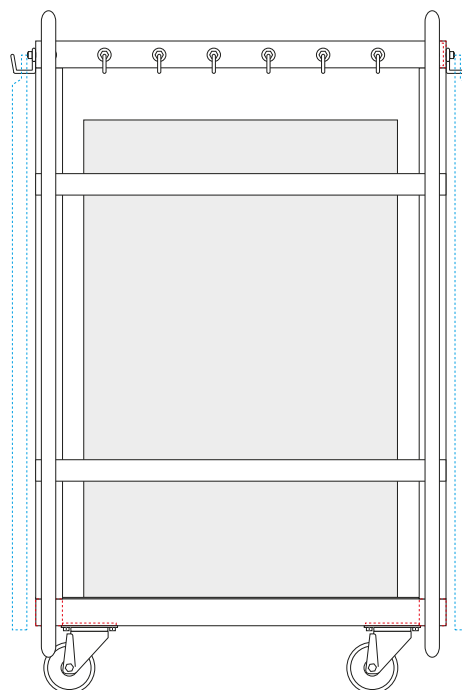

Rear profile

Signiatec

®



- Designed for specific purpose of clients requirements.
- Stainless steel construction.
- Complete with steps and handrail for safe/easy access to work platform.
- Powder coated paint finish available.
- Supplied with braked castors for transport ease from location to location. Truck locks for additional stability.

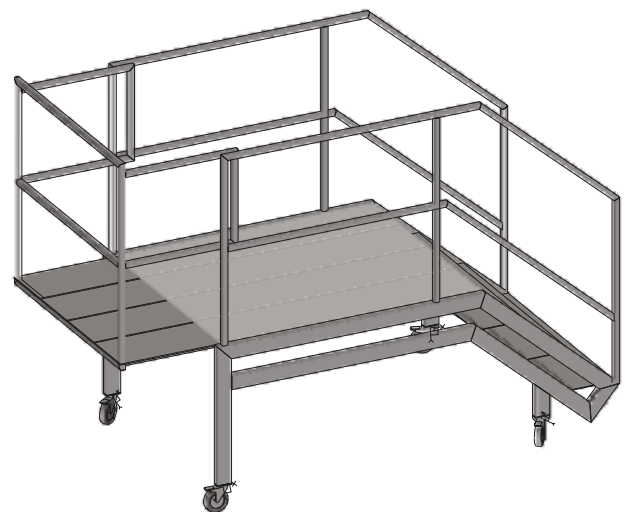
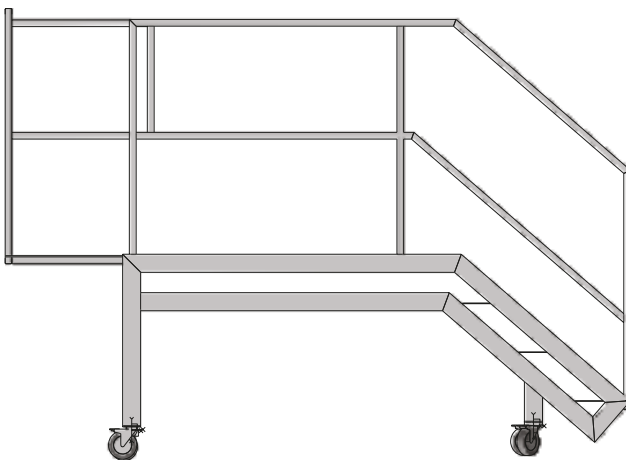
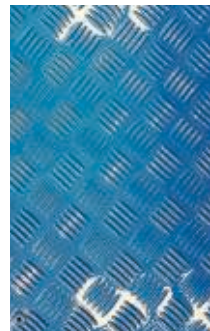

For more information contact us at:

Signiatec Ltd, Kiltorcan Business Park, Ballyhale, Co. Kilkenny, Ireland.

Telephone: +353 (0)56 7766648 Email: info@signiatec.ie Web: www.signiatec.ie

Signiatec

®



- Designed for specific purpose of clients requirements.
- Aluminium construction.
- Powder coated paint finish available.
- Supplied with adjustable levelling feet.

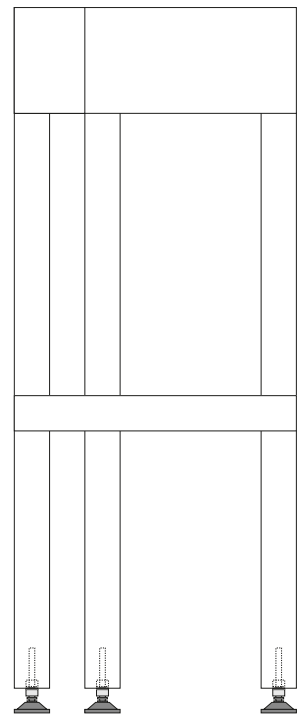
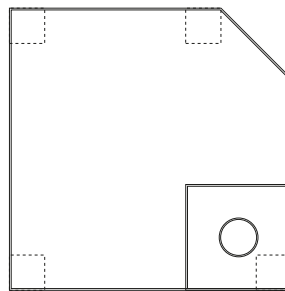

For more information contact us at:

Signiatec Ltd, Kiltorcan Business Park, Ballyhale, Co. Kilkenny, Ireland.

Telephone: +353 (0)56 7766648 Email: info@signiatec.ie Web: www.signiatec.ie